

1029A

Data Sheet
Genelec 1029A
Bi-amplified Monitoring System

GENELEC®





Applications

- Near Field Monitoring
- Audio Video Post Production
- Mobile Vans
- Home Theaters
- Project / Home Studios
- Digital Workstations
- Multimedia Production and Playback

1029A Active Monitoring System

System

The Genelec 1029A is a very compact bi-amplified active monitor system, which has performance comparable to much larger systems. The vented speaker enclosure contains an amplification unit. This unit includes an active electronic crossover, overload protection circuitry and two power amplifiers, one for each driver. The system's excellent dispersion and precise imaging, together with its compact size, make it ideal for near field monitoring, mobile vans, home studios, multimedia and home theaters.

The Genelec 1029A has been specially designed to have a sufficient LF extension (-3 dB at 68 Hz) for most monitoring applications. However if greater SPL's and a lower cutoff frequency are required, it can be complemented with the 7050A subwoofer, which has a lower cutoff point of 38 Hz.

Genelec's unique Directivity Control Waveguide (DCW) technology is used to provide excellent stereo imaging and frequency balance, even in difficult acoustic environments.

Versatile tone controls allow further matching of the system to its surroundings. A pair of 1029A's can produce peak acoustic levels of over 110 dB SPL at 1 m.

Integrated construction

The 1029A is very easy to set up and use, the only connections required are the mains supply and the line level input.

The integrated design allows the amplifiers and the drivers to be calibrated as a single unit, eliminating the effects of component tolerances and ensuring consistent quality. The rugged cast aluminium cabinet has rounded corners and a hard-wearing painted outer surface.

Crossover filters

The amplifier unit contains an active crossover, a feature more commonly used in large and expensive control room monitors. This is the ideal method for dividing the input signal between the driver units. The active crossover allows the overall response of the system to be optimized to an extent

impossible with a passive system. To maintain uniform frequency balance in differing acoustic environments, special calibrated controls are included in the active crossover network. These controls include treble 'tilt', bass 'tilt' and bass 'roll-off' switches.

Input connectors

The input is made via a balanced female XLR or a balanced 1/4" jack socket connector. The two input connectors offer great flexibility as they can be used in parallel. This offers the possibility of having two sources connected to the monitor at the same time. An additional configuration is using a single 1029A to monitor a stereo output. See figures 3 and 4.

The volume control is located on the front panel. This allows easy level matching with other audio equipment.

Amplifiers

The bass and treble amplifiers produce 40 W of output power each, with very low THD and IM distortion values. The amplifiers are designed to ensure the highest subjective

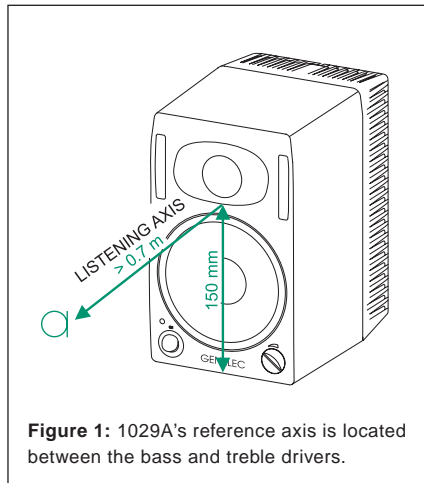

Figure 1: 1029A's reference axis is located between the bass and treble drivers.

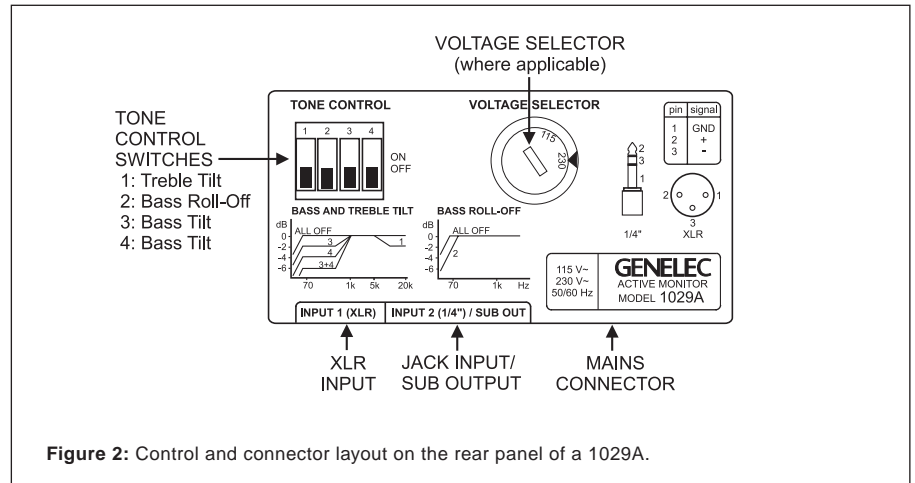

Figure 2: Control and connector layout on the rear panel of a 1029A.

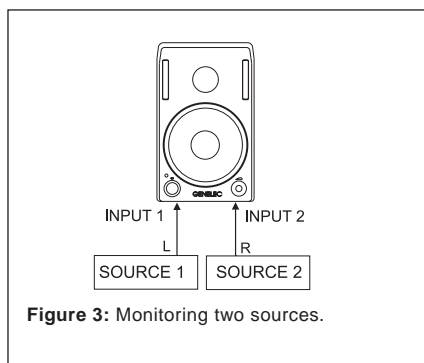

Figure 3: Monitoring two sources.

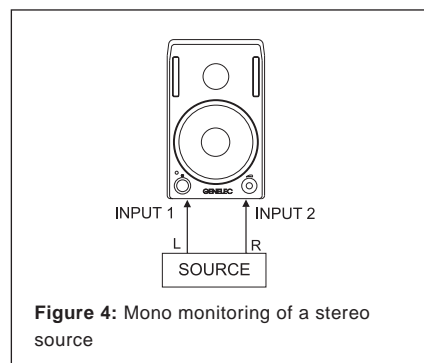

Figure 4: Mono monitoring of a stereo source

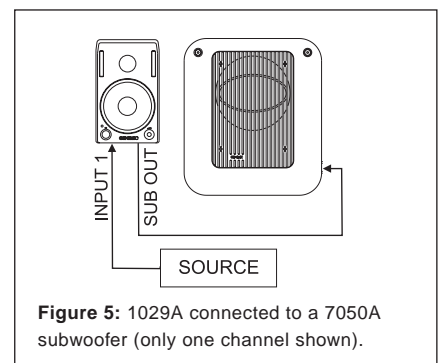

Figure 5: 1029A connected to a 7050A subwoofer (only one channel shown).

sound quality currently possible. The amplifier unit also contains a protection circuit that monitors the output levels and prevents any damage to the drivers. This makes the system immune to overloads and spurious signals.

Drivers

A 19 mm (3/4") metal dome tweeter is loaded by a DCW, and is used to reproduce the high frequencies. The DCW is integrated into the one piece cabinet front baffle.

The 130 mm (5") woofer is a bass cone driver mounted in a 4.5 litre vented cabinet. The -3 dB frequency is 68 Hz and the low frequency response extends down to 65 Hz (-6 dB).

Protective grilles are positioned in front of both drivers. Magnetic shielding is standard on the 1029A. Shielding is vital for applications such as video post production, where stray magnetic fields must be minimized.

DCW Technology

The revolutionary Directivity Control Waveguide (DCW) technology is a means of

greatly improving the performance of a direct radiating multi-way loudspeaker under normal listening conditions.

One of the basic aims is to match the performance of the drivers in terms of both frequency response and directivity. This results in a smoother overall frequency response on and off axis. In addition, the improved directivity control causes more direct sound and less reflected sound to be received at the listening position. This provides improved stereo imaging and ensures that the system is less sensitive to differing control room acoustics than conventional direct radiator design. The DCW Technology improves the drive unit sensitivity by +2 to +6 dB (depending on the particular application), thus also increasing the available system maximum sound pressure level.

Mounting

There are several possibilities for mounting the 1029A. On the base of the monitor is a 3/8" UNC threaded hole which can accommodate a standard microphone stand. There

is a provision for an Omnimount® size 50 bracket, for which two M6x10mm screws are required. Alternatively the speaker can be hung on M4 screws with suitable heads by one of the three keyhole slots on the backpanel. The speaker can be hung in a horizontal or vertical position. Friction pads are provided for placement on a shelf or a stand.

Options

The 1029A is available in three colours: black, grey and white. The driver's protective grilles, volume and power knobs and stickers on the back of the loudspeaker are black except for the bass driver grille on the white version, which is white.

Other options include wall and ceiling mounts, table stand and soft carrying bag. Ask your local Genelec dealer for more details.

1029A Data Sheet

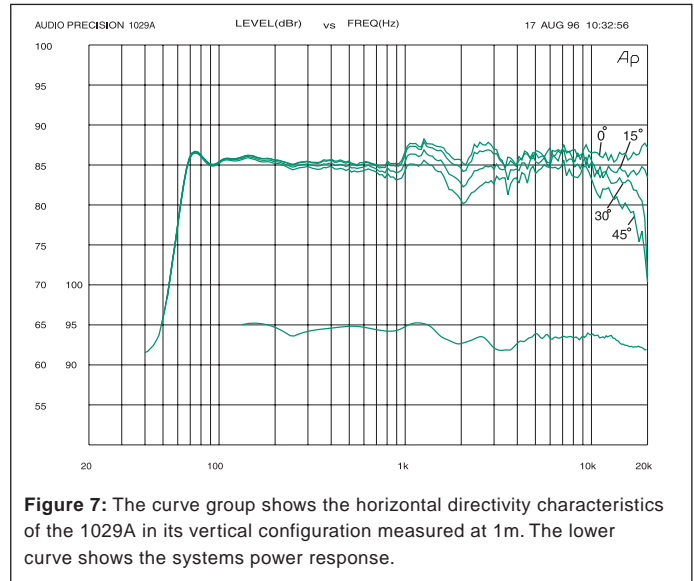
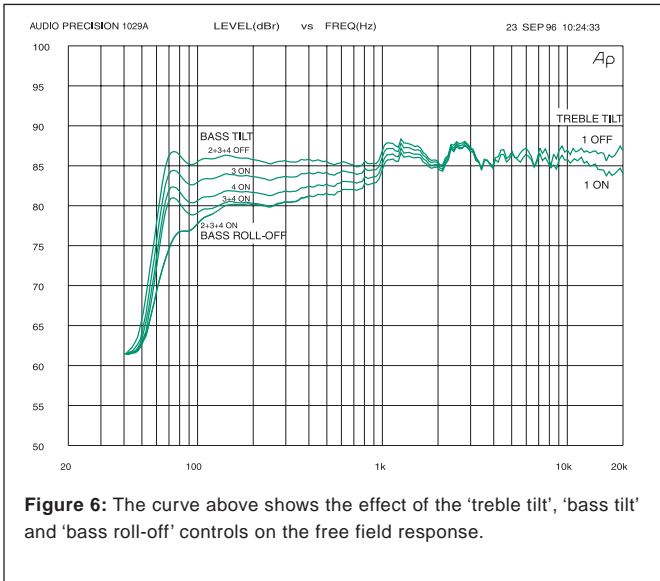

SYSTEM SPECIFICATIONS

Lower cut-off frequency, -3 dB:	≤ 68 Hz
Upper cut-off frequency, -3 dB:	≥ 20 kHz
Free field frequency response of system:	70 Hz - 18 kHz (± 2.5 dB)
Maximum short term sine wave acoustic output on axis in half space, averaged from 100 Hz to 3 kHz:	@ 1 m ≥ 100 dB SPL @ 0.5 m ≥ 106 dB SPL
Maximum long term RMS acoustic output in same conditions with IEC weighted noise (limited by driver unit protection circuit):	@ 1 m ≥ 98 dB SPL @ 0.5 m ≥ 104 dB SPL
Maximum peak acoustic output per pair on top of console, @ 1 m from the engineer with music material:	≥ 110 dB
Self generated noise level in free field @ 1m on axis:	≤ 10 dB (A-weighted)
Harmonic distortion at 85 dB SPL @ 1m on axis:	Freq: 75...150 Hz < 3% > 150 Hz < 1%
Drivers:	Bass 130 mm (5") cone Treble 19 mm (3/4") metal dome Both drivers are magnetically shielded
Weight:	5.7 kg (12.5 lb)
Dimensions:	Height 247 mm (9 3/4") Width 151 mm (5 15/16") Depth 191 mm (7 1/2")

CROSSOVER SECTION

Inputs:	Input 1: XLR female, balanced 10 kOhm Input 2: 1/4" Jack socket, balanced 10 kOhm
Input level for 100 dB SPL output at 1 m:	-6 dBu at volume control max
Volume control range:	>70 dB relative to max output
Subsonic filter below 68 Hz :	18 dB/octave
7050A/1091A Subwoofer output (input 2) at 100db SPL:	-23 dBu into 33kOhm load
Ultrasonic filter above 25 kHz:	12 dB/octave
Crossover frequency, Bass/Treble:	3.3 kHz
Crossover acoustical slopes:	24-32 dB/octave
Treble tilt control operating range:	0 to -2 dB @ 15 kHz
Bass roll-off control operating in a -6 dB step @ 85 Hz (to be used in conjunction with 7050A or 1091A subwoofer)	
Bass tilt control operating range in -2 dB steps:	0 to -6 dB @ 150 Hz
The 'CAL' position is with all tone controls set to 'off' and the input sensitivity control to maximum (fully clockwise).	

AMPLIFIER SECTION

Bass amplifier output power with an 8 Ohm load:	40 W
Treble amplifier output power with an 8 Ohm load:	40 W
Long term output power is limited by driver unit protection circuitry.	
Amplifier system distortion at nominal output:	
THD	≤ 0.08%
SMPTE-IM	≤ 0.08%
CCIF-IM	≤ 0.08%
DIM 100	≤ 0.08%
Signal to Noise ratio, referred to full output:	
Bass	≥ 90 dB
Treble	≥ 90 dB
Mains voltage:	100/200, 115/230 or 230 V according to region
Voltage operating range:	±10%
Power consumption:	Idle 9 VA Full output 80 VA

Genelec Document BBA29001a. Copyright Genelec Oy 1.2003. All data subject to change without prior notice



International enquiries:
Genelec Oy, Olvite 5
FIN-74100, Iisalmi, Finland
Phone +358 17 83 881
Fax +358 17 812 267
Email genelec@genelec.com

In the U.S. please contact
Genelec Inc., 7 Tech Circle
Natick, MA 01760
Phone +1 508 652 0900
Fax +1 508 652 0909
Email genelec.usa@genelec.com

www.genelec.com